

Full HD FIFO (First-In-First-Out) Memory

Applications

- HD video capturing and editing systems
- Switcher or format converter box
- Scan rate converters
- Time base correction (TBC)
- Frame synchronizer
- HD digital video camera buffering
- 1080p video stream data buffering

Description

The AL460 consists of 128Mbit of memory density, and is configured as 8,192K x 16 bits FIFO (First-In-First-Out), the optimized access scheme offers maximum R/W operating speed up to 150 MHz. The FIFO provides simple and easy-to-use user interfaces facilitating usage in a wide range of applications, such as Multimedia systems, video capture systems, and various video data buffering applications.

Features

- 128Mbit density configured as 8M x 16-bit input and output data bus width
- Supports NTSC, PAL and HDTV up to 1080p resolutions
- Independent 16-bit read/write data bus operations (different I/O data rates acceptable)
- High speed synchronous sequential access in maximum speed 150Mhz
- Input/Output enable control
- Supports double buffer mode (Upper and Lower frame access with 4M x16-bit in each frame) via frame select pins
- Polarity Selectable
- 2.5V and 3.3V power supply
- Standard LQFP-128 package

Ordering Information

Part number	Speed	Package	Power
AL460A-7-PBF	150MHz	LQFP-128	+2.5/3.3V
AL460A-13-PBF	75MHz	LQFP-128	+2.5/3.3V

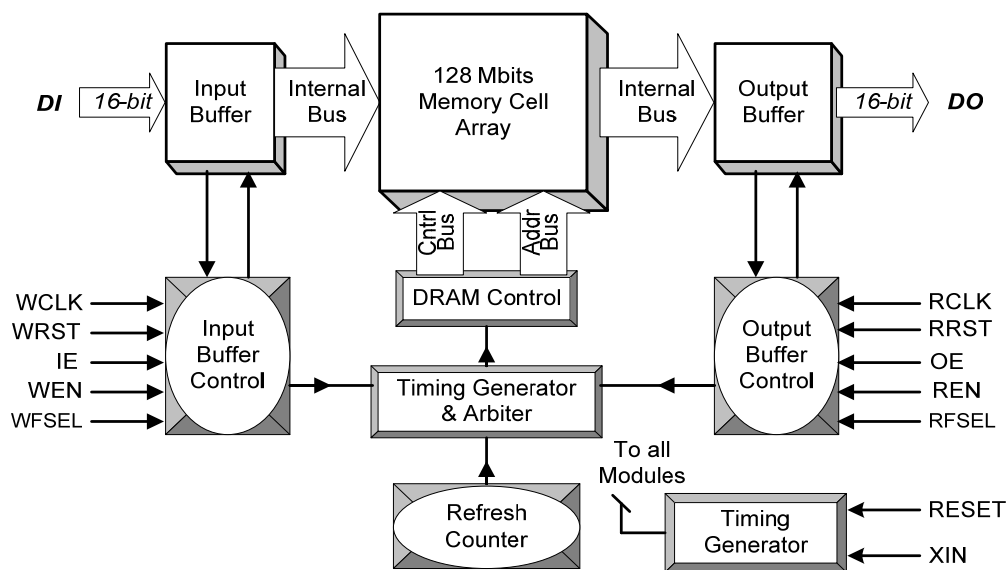

AL460 Block Diagram

The extensive memory size and high data-access-speed allow video frame capturing up to Full HD (1080p) resolution. Complementing the Double Buffer mode, 2 banks serve as upper and lower banks (with 4,096k x 16-bit of each bank), AL460 can be further manipulated into more sophisticated applications. The R/W operations of corresponding banks are acknowledged while high/low signals present at the bank control pins.

All AL460 FIFO specifics, like completely independent input and output controls, built-in address and pointer control circuits, bank switching and other management tasks provide data integrity during access and straightforward bus interface for a sequential data read/write that reduce inter-chip design efforts.

The Double-Buffer mode allocates video data capture without reading a mixed old and new data frames. The polarity control seamlessly matches the controller waveform without additional glue-logic.

The AL460 is also implemented with high performance process technologies with extended controller functions (write mask, read skip .. etc.); allowing easy operation of FIFO read/write for use in broadcasting systems, security systems, cameras, and many other applications.

Designed and manufactured using state-of-the-art technologies, AL460 achieved high performance and low power consumption AC characteristics (2.5/3.3V power supply), for the most sophisticated applications.

The chip is available as an LQFP-128 package; the small footprint keeps real estate of any designs to a minimum.

DISTRIBUTED BY:

www.averlogic.com

INFORMATION FURNISHED BY AVERLOGIC IS BELIEVED TO BE ACCURATE AND RELIABLE. HOWEVER, NO RESPONSIBILITY IS ASSUMED BY AVERLOGIC FOR ITS USE, OR FOR ANY INFRINGEMENTS OF PATENTS, OR OTHER RIGHTS OF THIRD PARTIES THAT MAY RESULT FROM ITS USE. NO LICENSE IS GRANTED BY IMPLICATION OR OTHERWISE UNDER ANY PATENT OR PATENT RIGHTS OF AVERLOGIC.